

Spacer Clip

Technical Drawing:

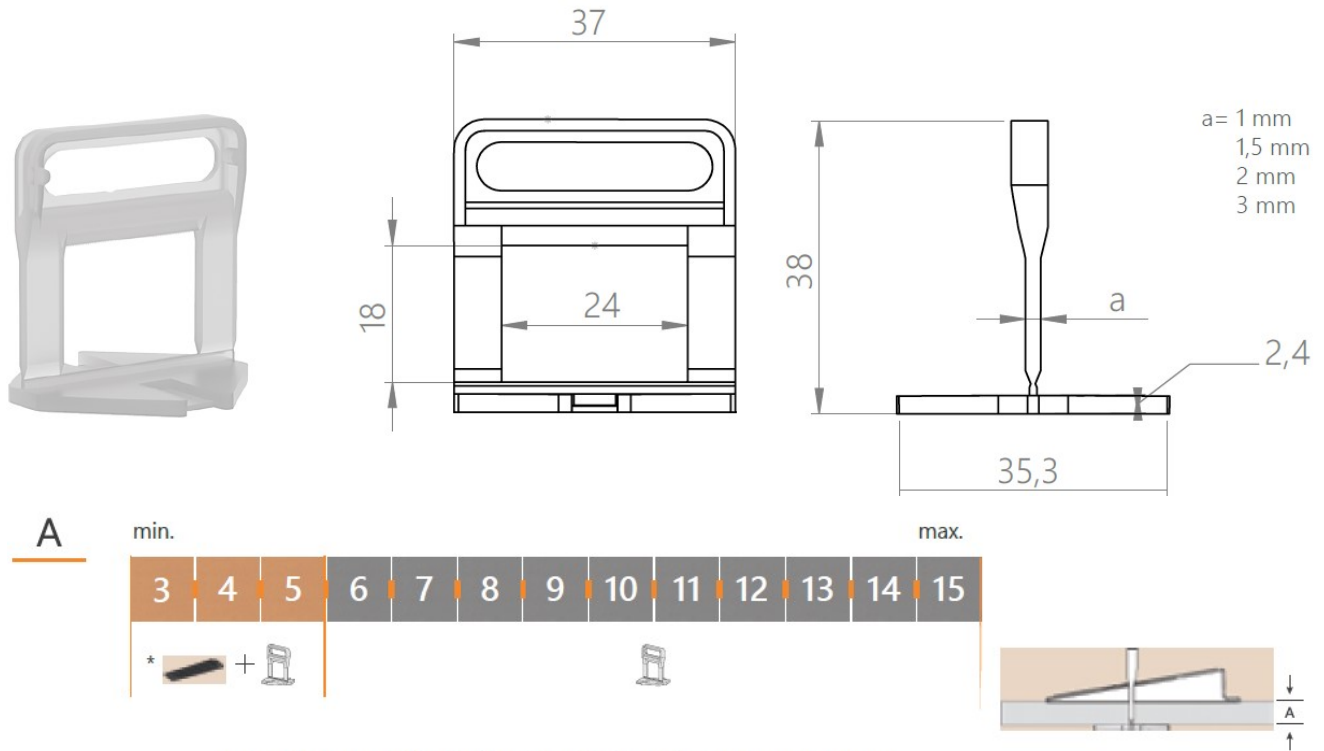

Spacer clips are used for all tiles with a thickness from 3 mm up to 15 mm.

(*) Wedge Separator must be used with tiles thinner than 6 mm.

Properties:

	Typical Value (*)	Unit	Test Method
Resin Properties			
Melt Flow Rate (230°C/2.16 kg)	11	g/10 min	ASTM D1238
Density	0.905	g/cm ³	ASTM D1505
Melting Point (DSC)	163	°C	ASTM D3418
Mechanical Properties(**)			
Tensile Strength at Yield	35	MPa	ASTM D638
Flexural Modulus, 23°C	1450	MPa	TS EN ISO 178
Izod Impact Strength, 23°C (notched)	20	J/m	ASTM D256
Rockwell Hardness	96	R-scale	ASTM D785
Thermal Properties			
Heat Deflection Temperature, 0.45 MPa	113	°C	ASTM D648

(*) These are typical properties only and are not to be construed as specifications. Customers should confirm results by their own tests.

(**) The values given are measured based on compression molded sheet.

Compliance to Regulations:

The formulation and production of PETOPLN EH102 conforms to the compositional requirements of the Commission Regulation (EU) No. 10/2011.

Health, Safety and Food Contact Regulations:

The detailed information of the PETOPLN EH102 is given in the Material Safety Datasheet and Food Contact Declaration of the product. Please contact your sales representative for the food contact application compliance (e.g. EU, FDA) and other regulatory documents.

Storage:

The product should be stored in a dry area with ambient temperature below 50°C. It should be kept away from sunlight, sparks, heat and flame. Inappropriate storage conditions can lead to colour changes and the deterioration in physical properties.

Recycling:

The product is not hazardous or toxic and is suitable for recycling. If it can't be recycled, the waste material can be disposed at a suitable landfill site, or at an approved waste incineration facility in accordance with applicable local, provincial, state and federal regulations.

Equus Industries Ltd
PO Box 601
Blenheim
Phone: 03 578 0214
Email: admin@equus.nz
Web: www.equus.nz
May 2020